

Copyright Tinkerforge GmbH 2015.  
 This documentation describes Open Hardware and is licensed under the CERN OHL v.1.1. (<http://phw.org/cernohl>). This documentation is distributed WITHOUT ANY EXPRESS OR IMPLIED WARRANTY, INCLUDING OF MERCHANTABILITY, SATISFACTORY QUALITY AND FITNESS FOR A PARTICULAR PURPOSE. Please see the CERN OHL v.1.1 for applicable conditions

DRILL DRILL  
 DRILL DRILL

PowerSupply	Stack	Bricklets	Sensor	LEDs
powersupply.sch	stack.sch	bricklets.sch	sensor.sch	leds.sch

Copyright (©) 2015, B.Nordmeyer <bastian@tinkerforge.com>  
 Licensed under CERN OHL v.1.1  
**Tinkerforge GmbH**  
 Sheet: /  
 File: imu.sch  
**Title: IMU Brick**

Size: A4	Date: 17 mar 2015	Rev: 2.0
KiCad E.D.A. kicad (2015-03-18 BZR 5525)-product		Id: 1/6

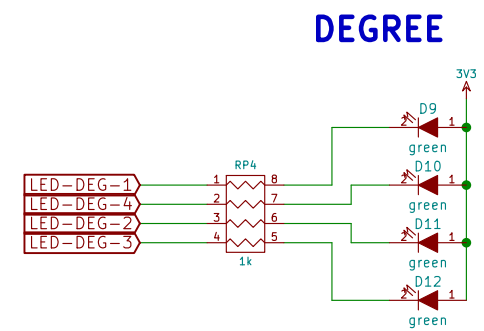
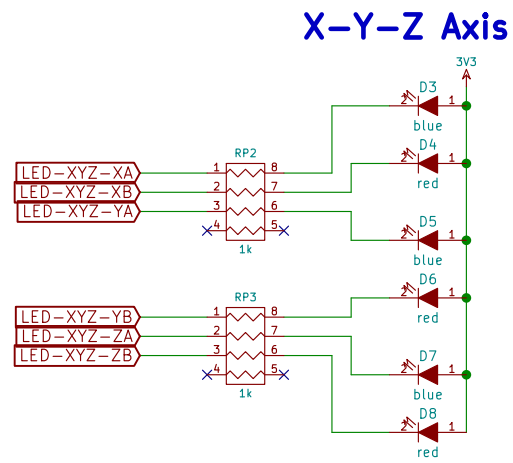

Copyright (©) 2015, B.Nordmeyer <bastian@tinkerforge.com>  
 Licensed under CERN OHL v.1.1

**Tinkerforge GmbH**

Sheet: /LEDs/  
 File: leds.sch

**Title: IMU Brick**

Size: A4 Date: 17 mar 2015  
 KiCad E.D.A. kicad (2015-03-18 BZR 5525)-product

**Rev: 2.0**  
 Id: 2/6

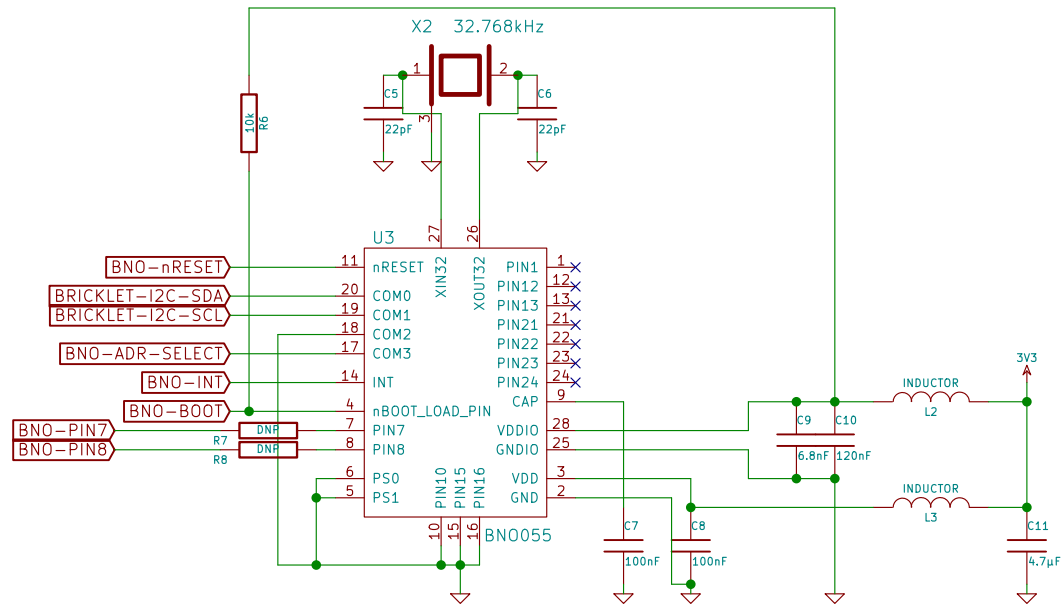

Copyright (©) 2015, B.Nordmeyer <bastian@tinkerforge.com>  
 Licensed under CERN OHL v.1.1

**Tinkerforge GmbH**

Sheet: /Sensor/  
 File: sensor.sch

**Title: IMU Brick**

Size: A4 Date: 17 mar 2015  
 KiCad E.D.A. kicad (2015-03-18 BZR 5525)-product

**Rev: 2.0**  
 Id: 3/6

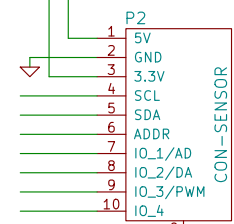
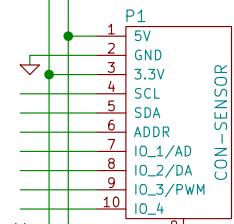
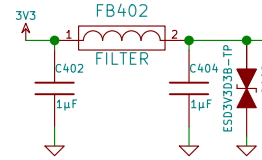
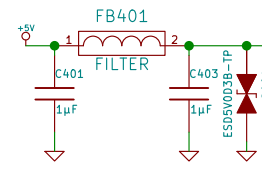

Copyright (©) 2015, B.Nordmeyer <bastian@tinkerforge.com>  
 Licensed under CERN OHL v.1.1

**Tinkerforge GmbH**

Sheet: /Bricklets/  
 File: bricklets.sch

**Title: IMU Brick**

Size: A4 Date: 17 mar 2015  
 KiCad E.D.A. kicad (2015-03-18 BZR 5525)-product

**Rev: 2.0**  
 Id: 4/6

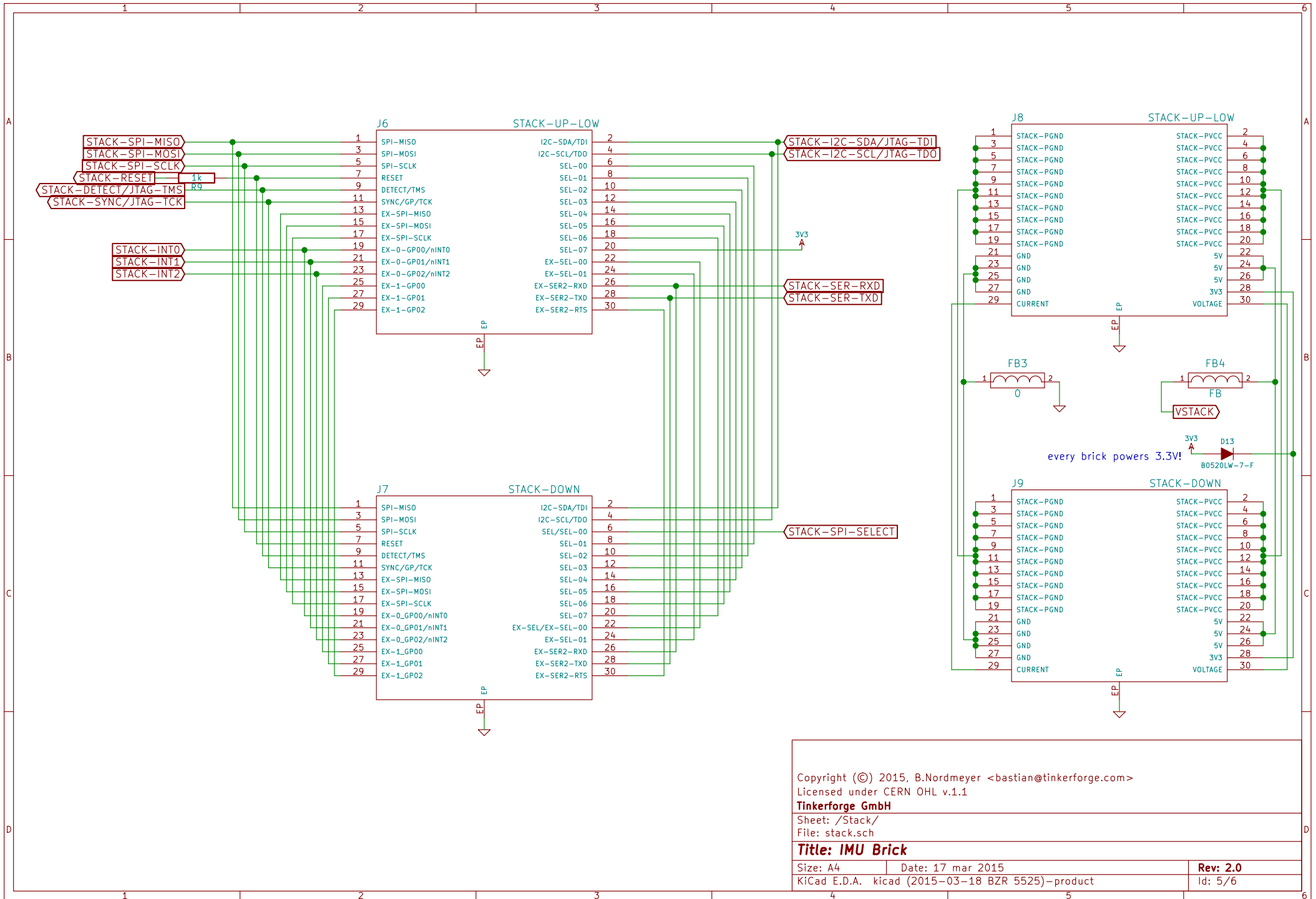

Copyright (©) 2015, B.Nordmeyer <bastian@tinkerforge.com>  
 Licensed under CERN OHL v.1.1

**Tinkerforge GmbH**

Sheet: /Stack/

File: stack.sch

**Title: IMU Brick**

Size: A4 Date: 17 mar 2015  
 KiCad E.D.A. kicad (2015-03-18 BZR 5525)-product

**Rev: 2.0**  
 Id: 5/6

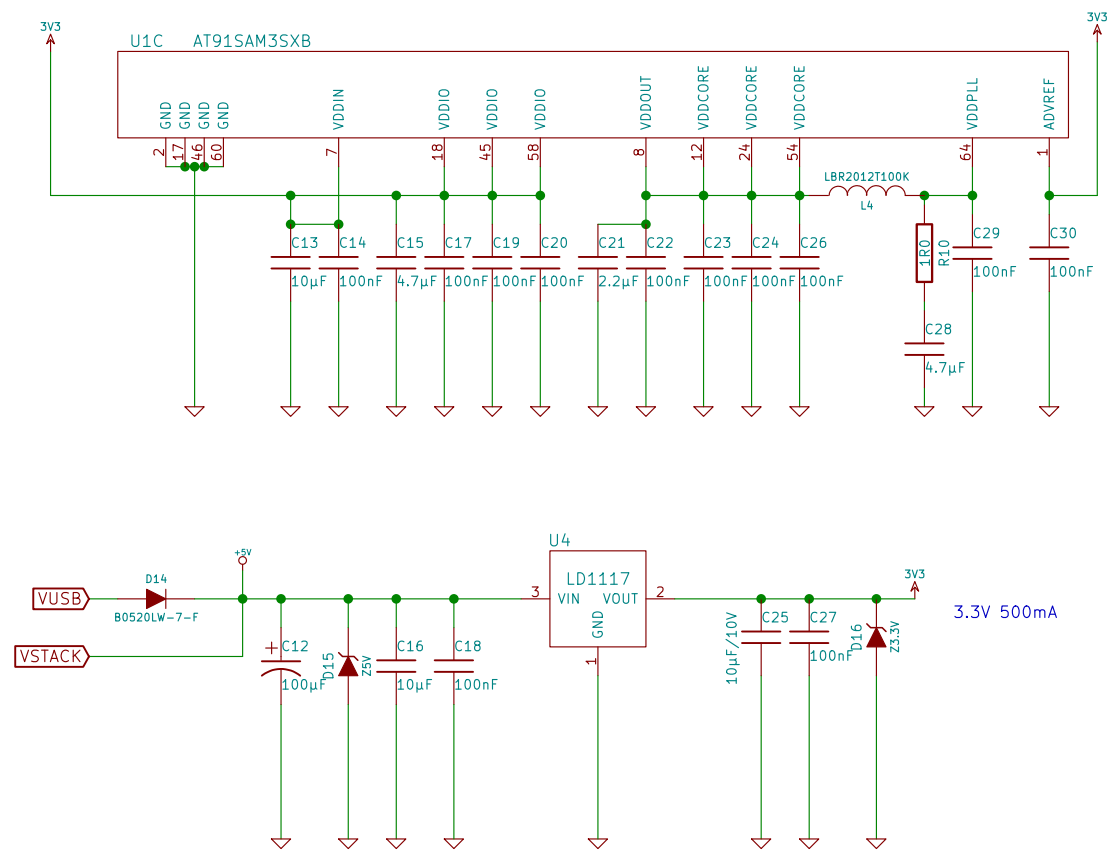

Copyright (©) 2015, B.Nordmeyer <bastian@tinkerforge.com>  
 Licensed under CERN OHL v.1.1

**Tinkerforge GmbH**

Sheet: /PowerSupply/  
 File: powersupply.sch

**Title: IMU Brick**

Size: A4	Date: 17 mar 2015	<b>Rev: 2.0</b>
KiCad E.D.A. kicad (2015-03-18 BZR 5525)-product	Id: 6/6	